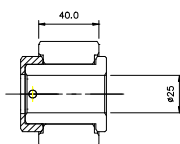
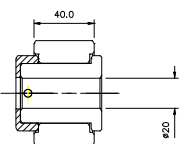
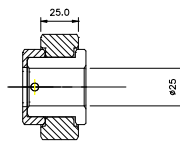
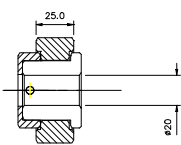

EQUIPMENT DATA SHEET – 1A

POWERED ROLLER CONVEYOR
STANDARD POWER AND FREE ROLLER ASSEMBLY

- **Components produced from authentic tooling.**
- **Component parts manufactured from sintered steel.**
- **Assembly supplied with three components –**
 - **Collar - located on the cross driveshaft.**
 - **Roller - positioned on the collar detail – free rotating.**
 - **End Cap - located on the collar to retain the roller in position.**
- **The complete assembly is pinned to the cross drive shaft, using a roll pin locating the Cap and Collar details.**

POWER AND FREE ROLLER ASSEMBLY TYPES

<p>MAYSTD 0201</p>  <p>0141/1/A</p>	<p>MAYSTD 0202</p>  <p>0141/1/B</p>
<p>MAYSTD 0203</p>  <p>0141/2/A</p>	<p>MAYSTD 0204</p>  <p>0141/2/B</p>

CONVEYOR CROSS SECTION

